

**KL**

**7000/8000LY**

Heavy Duty, Large Capacity, Y-axis CNC Turning Center

WIA Machine Tools CNC Turning Center

**WIA** MACHINE TOOLS

# Technical Leader

The KL7000/8000LY, Y-axis CNC turning center designed with WIA machine tools's engineering expertise to maximize productivity by enhancing rigidity and accuracy of machining.

		KL7000LY	KL8000LY
Max. Turning Dia.	mm(in)	Ø920 (36.2")	
Max. Turning Length	mm(in)	3,250 (128")	
Chuck Size	inch	[Opt. 24"]	[Opt. 32"]
Bar Capacity	mm(in)	Ø165 (6.5")	Hydraulic : Ø239 (9.4") Air/Independent : Ø319 (12.6")
Spindle Speed (rpm)	r/min	1,500	700
Motor (Max/Cont.)	kW(HP)	45/37 (60/50)	
Travel (X/Y/Z)	mm(in)	500/220 (±110)/3,280 (19.7"/8.7" (±4.3"))/129"	
No. of Tool	EA	BMT85 : 12	

[ ]: Option

# KL

## 7000/8000LY

Heavy Duty, Large Capacity, Y-axis CNC Turning Center

- Multi-tasking operation with wedge type Y-axis BMT85 turret
- Flat bed with rigidity increased by 25% compared to slant type bed
- 3 Step gear box type main spindle (KL8000LY : 2 step)
- Main spindle thermal displacement minimized
- Rigidity secured through box guideways on all axis
- Structure designed for machining long shafts and pipes with maximum turning length of 3,250mm (128")



# 01 BASIC STRUCTURE

High Rigid Bed & Structure for Heavy Duty Cutting CNC Turning Center



### BMT85 Mill Turret

- 3,000 rpm
- Collet Size : Ø34 (1.3")/ER50

### High Precision Spindle

- KL7000LY : 1,500 r/min
- KL8000LY : 700 r/min
- C-Axis Control : 0.001°
- Big Bore Spindle (KL8000LY)

3,250 mm (128")

Ø920 (36.2")

### Spindle Gear Box

- KL7000LY : 3 Step Gear
- KL8000LY : 2 Step Gear

### Built-in Tail Stock

- Taper : MT#6
- Quill Travel : 200 (7.9")

**KL7000/8000LY features the largest machining area in its class, increasing the size of parts that can be machined.**

# POWERFUL CUTTING CAPABILITY & WIDE CUTTING AREA

## ALL-IN-ONE TYPE OF BED

### High Rigidity Flat Bed Structure

KL7000/8000LY is designed with a unique structure analysis only offered by Hyundai Wia in the flat bed structure unlike the existing slant bed, resulting in improvements in strong and heavy-duty cutting capability.

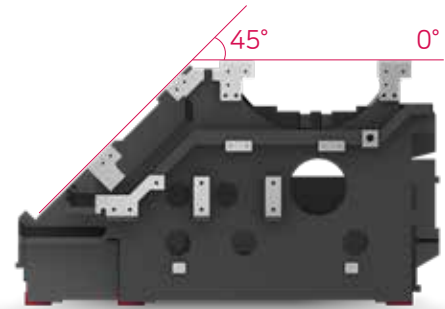

Up to **25%** additional rigidity compared to slant type bed

## GUIDEWAY

### Box Guideway

The KL7000/8000LY, specialized in machining large products, features box guideways in all axis and gear driven main spindle. The series demonstrates unsurpassed performance in heavy duty cutting.

### Ball Screw

Travel is stabilized by fixing both ends of the ball screw with double anchored method. In particular, a large diameter ball screw with proper preload reinforces sturdiness and resistance to thermal displacement.



**Rapid Traverse Rate (X/Y/Z)**

**12/10/12** m/min

(472/394/472 ipm)

**Travel (X/Y/Z)**

**500/220/3,280** mm

(19.7"/8.7"/129")

KL7000/8000LY

# 02 HIGH PRECISION SPINDLE

Long Lasting, High Accuracy & Excellent Performance CNC Turning Center



## Spindle Specifications

MODEL	Spindle Speed	Motor (Max./Cont.)	Torque (Max./Cont.)	Driving Method
KL7000LY	1,500 rpm	45/37 kW (60/50 HP)	6,928/5,700 N·m (5,109.8/4,204.1 lbf·ft)	Belt + 3 Step Gear
KL8000LY	700 rpm	45/37 kW (60/50 HP)	7,045/5,795 N·m (5,196.1/4,274.2 lbf·ft)	Belt + 2 Step Gear

# HEAVY DUTY CUTTING & HIGH ACCURACY

## MAIN SPINDLE

### Spindle Ideal for Heavy Cutting

To accomplish stability even during the heavy-duty cutting, the spindle is designed with a combination of P4 level double cylindrical roller bearings and angular bearings.

The spindle is equipped with a high torque gear box showing the strength in the heavy-duty cutting. In addition, heat dissipation ribs and fan are attached to the front/rear side making heat discharge faster.

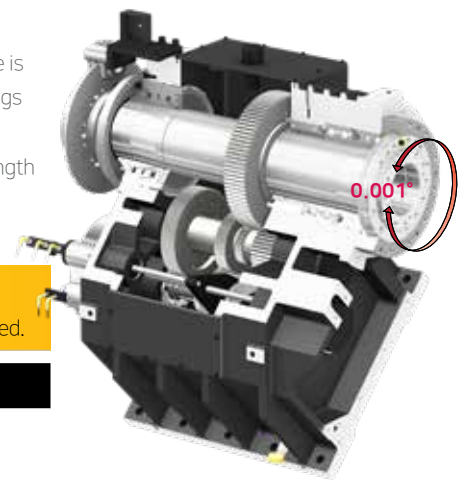

#### Spindle Gear Box

Gear shift of spindle provide stability and high torque during low speed.

KL7000LY

KL8000LY

3 Step Gear

2 Step Gear

### C-Axis Control

The C-axis is capable of 0.001° control when milling turret is applied. Machining capability is strengthened with turning and milling operations.

※ Prior consultation is required when applying spindle contouring control for gear driven spindle.



## BIG BORE SPINDLE (KL8000LY)

Max. Spindle Bore **Ø320 (Ø12.6")** show excellent performance in machining large cylindrical parts for oil and gas industry.

### Air Chucking System **OPTION**

A dual chuck design - one on each end of the spindle - offers superior support of the workpiece such as long shafts or pipe.



KL7000/8000LY

# 03 SERVO TURRET

High speed, High Accuracy, Highly Reliable Servo Turret

## Mill Turret Specifications

ITEM	Speed	Motor (Max./Cont)	Torque (Max./Cont)	Collet Size
BMT85	3,000 rpm	11/7.5 kW (15/10 HP)	140/95.4 N·m (103.3/70.4 lbft·ft)	ER50 (Ø34)

<b>No. of Tools</b>	<b>Tool Size (O.D/i.D)</b>	<b>Indexing Time</b>
12 <sub>EA</sub>	□32/Ø80 mm (Ø1 1/4"/Ø3")	0.3 <sub>sec</sub>

# MACHINING PROCESS WITH ONLY ONE INITIAL SETTING

## MILL TURRET

### BMT85 Turret

The large 12-station BMT turret enables the KL7000/8000LY to perform high accuracy milling operations in a single set-up. The BMT turret is driven by a high torque servo motor with a 0.3 second indexing time in either direction.

STRAIGHT MILLING HEAD



ANGULAR MILLING HEAD



### Mill Tool Holder

Machining capabilities have been increased with the addition of a straight milling head, which can remove material from the side of the workpiece, and an angular milling head, which can perform i.D. operations.



## Y-AXIS

### Wedge Type Y-axis Structure

The KL7000/8000LY is designed with a wedge type Y-axis that is transferred by the simultaneous operation of the Ys-axis and the X-axis. In addition, excellent rigidity makes possible to perform superb quality when machining a heavy-duty cutting.

Y-axis Rapid Traverse Rate : **10** m/min

Y-axis Travel : **220** {±110} mm (8.7" {±4.3"})

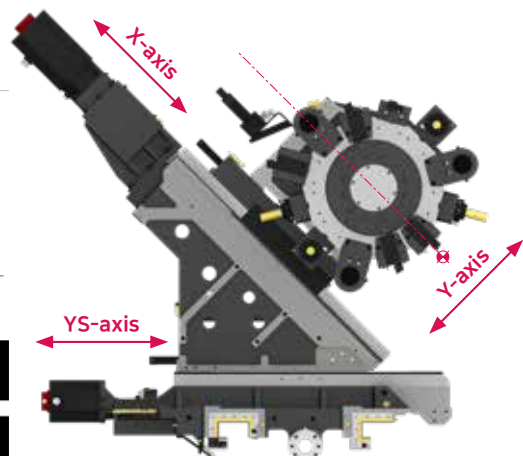

# 04 USER CONVENIENCE

Various Devices for User Friendly

## TAIL STOCK

### Built-In Tail Stock (Programmable)

The built-in tail stock ensures high accuracy even during heavy duty cutting and can be controlled automatically or manually.

unit : mm(in)

Taper	Quill Dia.	Quill Travel	Travel
MT#6	Ø180 (7.1")	200 (7.9)	3,200 (126")

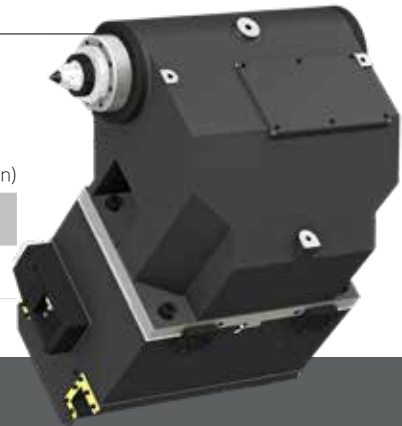

### Steady Rest **OPTION**

For long parts, such as shafts, the optional steady rest increases rigidity and minimizes vibration. When using the programmable hydraulic work rest provided as an option, the position of the work rest can be adjusted according to the shape of the product using the alignment pin connected to the turret. This enhances the efficiency of the machining operation.

※ Steady rest contact dia. : Max. Ø510 (Ø20.1") for SMW K.6.1

## MACHINING SUPPORT SYSTEM



### Automatic Q-Setter

Cutting tools are calibrated quickly and accurately with the addition of a q-setter. Each tool tip is touched off manually using a sensor that inputs the position automatically.

※ (KL8000LY : Manual Q-Setter)



### Linear Scale **OPTION**

Linear scales increase positioning accuracy and reduce distortion caused by thermal growth, thus ensuring a more accurate finished part



### Rear Chuck **OPTION**

The rear chuck option enables long products such as long shaft or pipes to be processed in a stable condition. (KL8000LY)

Optional

## COOLANT UNIT

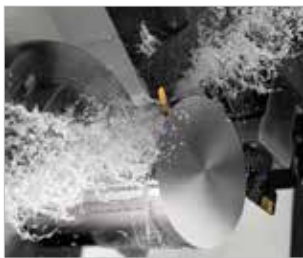

Standard Coolant (Nozzle)



Chuck Coolant (Upper Chuck)



Chuck Air Blow (Upper Chuck)



Gun Coolant

## CHIP DISPOSAL SOLUTION

### Chip Conveyor

Timely and effective disposal of chips will enhance productivity as well as the working environment.



Hinge	Chip Type : Roughing Chip, Long Chip, Chip complex	Material : SS41, 45C, Cast Steel	Front-Right Direction
	Highly efficient when disposing a lot of chips. Capable of handling stringy chips..		
Scraper	Chip Type : Finely broken chip blown out	Material : cast Iron, Nonferrous	
	Convenient for shortly cut chips.		
※ Drum Filter	Chip Type : Powder, Micro Chip	Material : AL	
	Advantageous in precision, as the chips do not flow in to the coolant nozzle.		

※ When ordering a drum filter chip conveyor, prior consult with hyundai wia's sales person.

# 05 FANUC - SMART PLUS

The Compatible All-round Control



## 15" Touch-type Monitor as a standard

Smart Machine Control

Conversational Program

i-HMI

Part Program Storage

No. of Registerable Programs

Fast Cycle Time Technology

Fine Surface Technology

Smart Servo Control Technology

SmartGuide-i

Machining-aid Function

5120M (2MB)

1000 EA

## Servo Learning Oscillation Function for Chip Breaking **OPTION**

- **Machining Method** : The tool cuts the workpiece moving in a zigzag pattern. (Oscillating) → Air cut section occurs → Long chips break
- **Advantage** : Increase tool life, Enhance surface finishing, Improve chip disposal
- **Machine** : All turning centers with FANUC controller (Option)

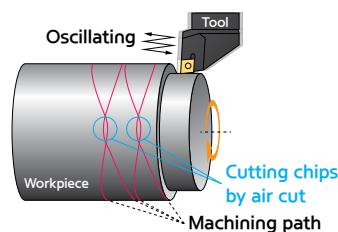

(Developed special screen page for servo learning oscillation function / Even when this function is applied, the cycle time remains same.)

## 8Ch. Thermal displacement compensation **OPTION**



Control Software

Thermal Sensor

Spindle thermal displacement error correction

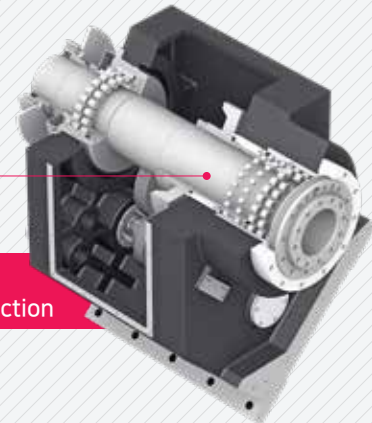

Thermal Sensor

Structure thermal displacement error correction

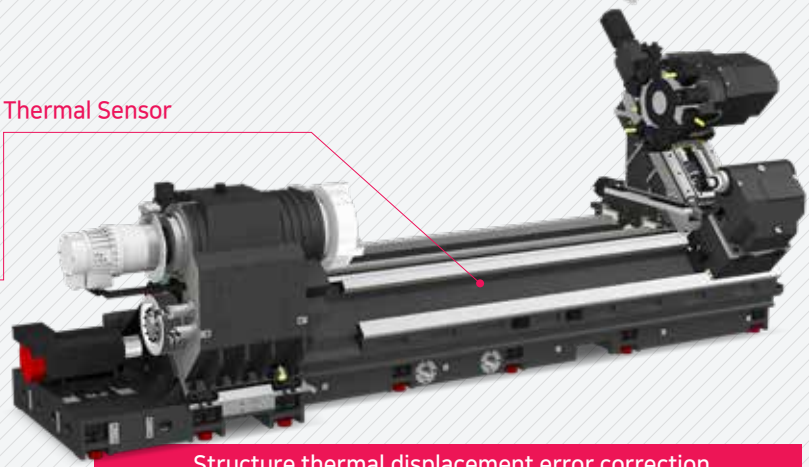

Machine tools generate thermal displacement due to heat during machining. WIA machine tools detect thermal changes through thermal sensors installed on the main thermal sources of the machine. In addition, a thermal displacement compensation device that predicts the amount of thermal displacement according to the amount of thermal change and provides a command to the motor with a compensated value to maintain consistent precision is provided as an option.

## SMART CNC (FANUC Smart Plus)



### 1. Dialogue Program (Smart Guide-i)

This software offers the maximum user convenience through dialogue manipulation from setup to processing. This includes writing processing programs and simulation checks.

### 2. LAUNCHER

This software offers shortcuts for quick access to specialized features and frequently used features.

# SPECIFICATIONS

## Standard & Optional

Spindle		KL7000LY	KL8000LY
Main Spindle	24"	○	-
Hollow Chuck 3 Jaw	32"	-	○
Main Spindle	24"	-	-
Solid Chuck 3 Jaw	32"	-	-
Big Bore Air Chuck (Dual)	27"	-	○
Big Bore Independent Chuck (Dual)	24"	-	○
Standard Soft Jaw (1set)		○	○
Chuck Clamp Foot Switch		●	●
2 Steps Hyd, Pressure Device		○	○
Spindle Inside Stopper		☆	☆
5" Index		☆	☆
Cs-Axis (0.001")		●	●
Chuck Open/Close Confirmation Device		○(CE:●)	○(CE:●)
2 Steps Chuck Foot Switch		○	○
<b>Turret</b>			
Tool Holder		●	●
Mill Turret	BMT85	●	●
Straight Milling Head	Adaptor Type	●	●
Angular Milling Head	Adaptor Type	●	●
Boring Sleeve		●	●
Drill Socket		○	○
U-Drill Cap		●	●
Long Boring Bar I.D Holder		○	○
Angle Head		☆	☆
<b>Tail Stock &amp; Steady Rest</b>			
Built-in Tail Stock		●	●
Programmable Tail Stock		●	●
Manual Type Steady Rest		☆	☆
Manual Type	1Set	-	-
Hyd. Steady Rest	2Sets	-	-
Programmable	1Set	○	○
Hyd. Steady Rest	2Sets	○	○
Fixed center		●	●
2 Steps Tail Stock Pressure System		☆	☆
Quill Forward/Reverse Confirmation Device		●	●
Tail Stock Foot Switch		●	●
<b>Coolant &amp; Air Blow</b>			
Standard Coolant (Nozzle)		●	●
Bed Flushing Coolant		●	●
Chuck Coolant (Upper Chuck)		○	○
Gun Coolant		○	○
Spindle Thru Coolant (Only for Special Chuck)		☆	☆
Thru Coolant for Live Tool		-	-
Chuck Air Blow (Upper Chuck)		○	○
Tail Stock Air Blow (Upper Tail Stock)		☆	☆
Turret Air Blow		☆	☆
Air Gun		○	○
Spindle Thru Air Blow (Only for Special Chuck)		☆	☆
High Pressure Coolant	6Bar (87psi)	●	●
	20Bar (290psi)	○	○
	70Bar (1,015psi)	○	○
Power Coolant System (For Automation)		☆	☆
Coolant Chiller		☆	☆
<b>Chip Disposal</b>			
Coolant Tank	620 ℓ (163.8 gal)	●	●
Chip Conveyor (Hinge/Scraper)	Front (Right)	○	○
	Front (Rear)	-	-
Special Chip Conveyor (Drum Filter)		☆	☆
Chip Wagon	Standard (180 ℓ [47.5 gal])	○	○
	Swing (200 ℓ [52.8 gal])	○	○
	Large Swing (290 ℓ [76.6 gal])	○	○
	Large Size (330 ℓ [87.2 gal])	○	○
	Customized	☆	☆

● : Standard ○ : Option ☆ : Prior Consultation - : Non Applicable

Safety Device		KL7000LY	KL8000LY
Back Spin Torque Limiter (BST)		●	●
Total Splash Guard		●	●
Chuck Hydraulic Pressure Maintenance Interlock		☆	☆
<b>Electric Device</b>			
Call Light	1Color : ●	●	●
Call Light & Buzzer	3Color : ●●●	○	○
Electric Cabinet Light		○	○
Remote MPG		○	○
Work Counter	Digital	○	○
Total Counter	Digital	○	○
Tool Counter	Digital	○	○
Multi Tool Counter		○	○
Electric Circuit Breaker		○	○
AVR (Auto Voltage Regulator)		☆	☆
Transformer	70kVA	○	○
Auto Power Off		○	○
<b>Measurement</b>			
Manual Q-Setter		○	○
Automatic Q-Setter		●	-
Work Close Confirmation Device (Only for Special Chuck)	TACO	☆	☆
Work Setter	SMC	☆	☆
Linear Scale	X Axis	○	○
	Z Axis	○	○
Coolant Level Sensor (Only for Chip Conveyor)		☆	☆
<b>Environment</b>			
Air Conditioner		○	○
Oil Mist Collector		☆	☆
Oil Skimmer		○	○
MQL (Minimal Quantity Lubrication)		☆	☆
<b>Fixture &amp; Automation</b>			
Auto Door	Standard	○	○
	High Speed	☆	☆
Auto Shutter (Only for Automatic System)		-	-
Sub Operation Panel		☆	☆
Bar Feeder Interface		○	○
Bar Feeder (FEDEK)		☆	☆
Extra M-Code 4ea		○	○
Automation Interface		☆	☆
I/O Extension (IN & OUT)	16 Contact	○	○
	32 Contact	○	○
Parts Catcher	Main SP.	-	-
Turret Work Pusher (For Automation)		☆	☆
<b>Hyd. Device</b>			
Standard Hyd. Cylinder	Hollow	●	●
Standard Hyd. Unit	50bar(725.2psi) / 63 ℓ (16.6 gal)	●	●
<b>S/W</b>			
Automatic CAM (HW-ACAM)		-	-
Dialogue Program (HW-DPRO)		○	○
DNC software (HW-eDNC)		○	○
Smart Guide-i		● (F32i-B : ☆)	● (F32i-B : ☆)
Smart S/W		☆	☆
<b>ETC</b>			
Tool Box		●	●
Customized Color	Need Munsel No.	☆	☆
CAD & CAM		☆	☆

※ 4 channel of TDC(Thermal Displacement Compensation) device is recommended, when more than 6 bar of high pressure coolant is applied, for the high quality machining.  
Specifications are subject to change without notice for improvement.

# SPECIFICATIONS

## Spindle Output/Torque Diagram

### KL7000LY 1,500 rpm

Power(kW [HP])

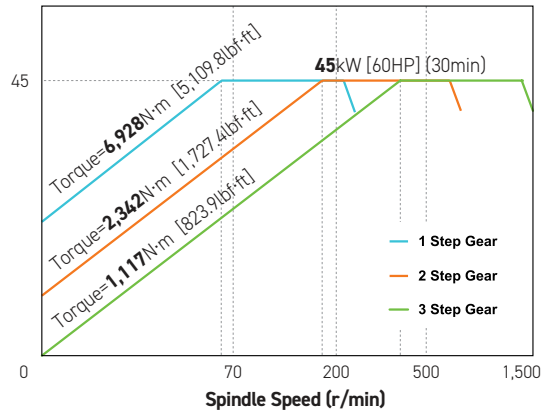

### KL8000LY 700 rpm

Power(kW [HP])

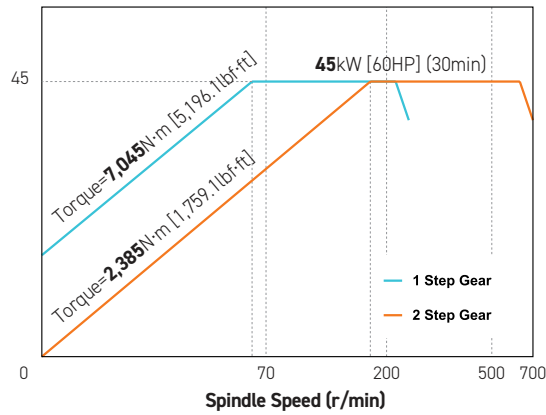

### Mill Turret 3,000 rpm

Power(kW [HP])

Torque (N·m [lbf·ft])

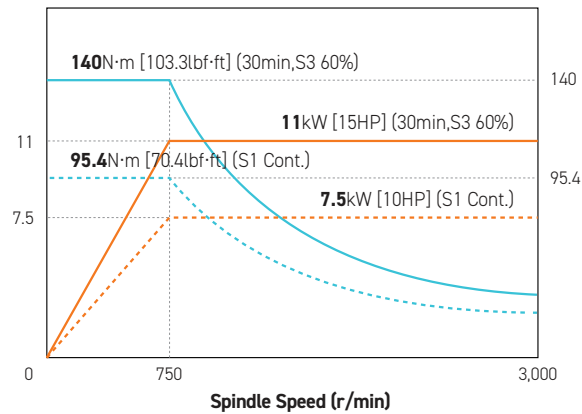

# SPECIFICATIONS

## External Dimensions

unit : mm(in)

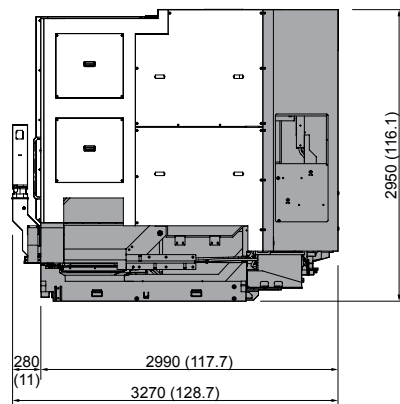
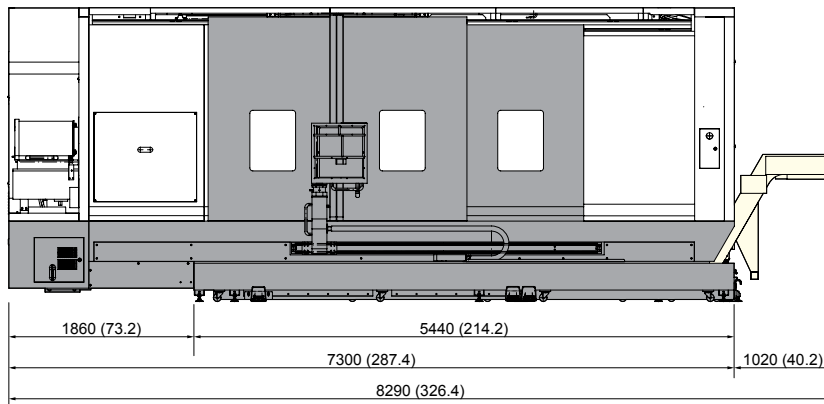
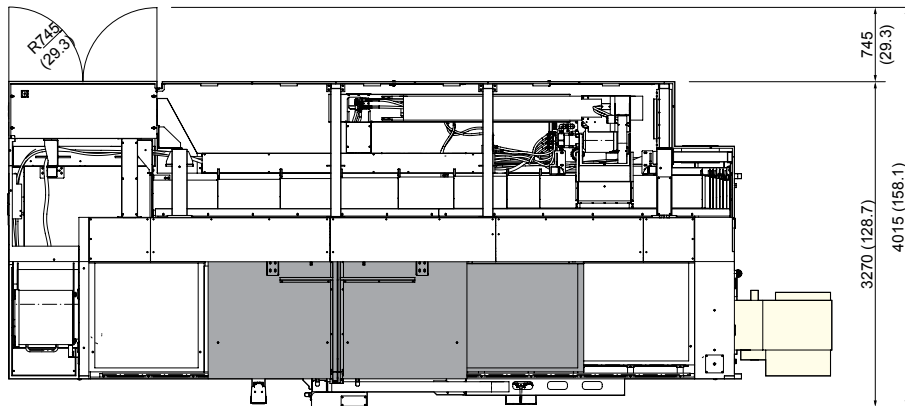



# SPECIFICATIONS

## Tooling System

unit : mm(in)

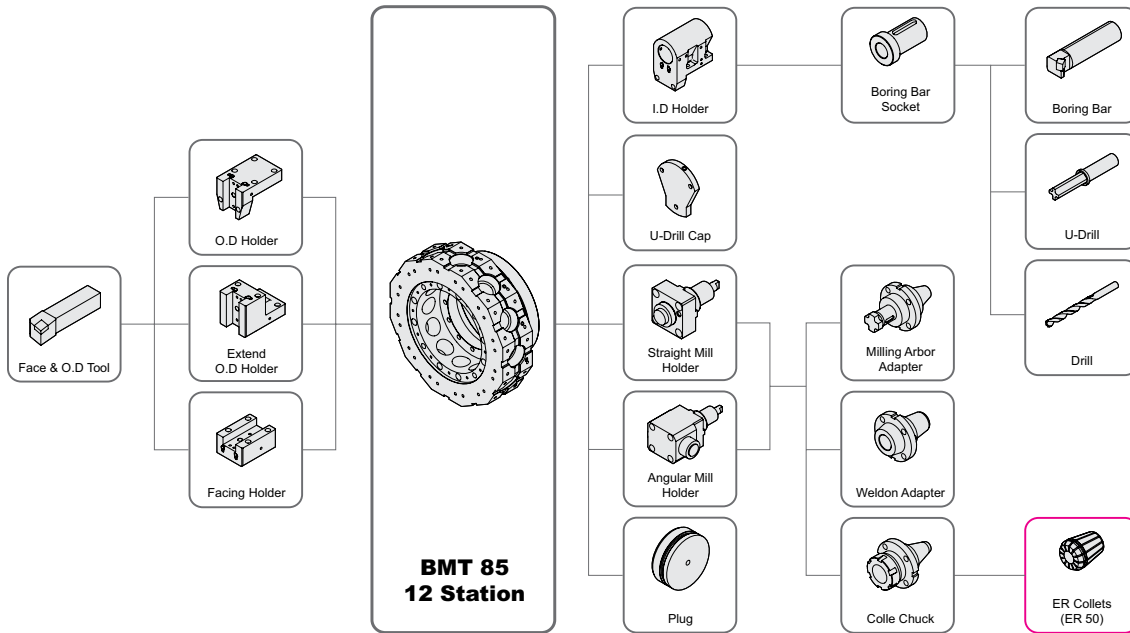

## KL7000/8000LY Tooling Parts Detail

ITEM			KL7000LY / KL8000LY	
			mm Unit	inch Unit
Turning Holder	O.D Holder	Right/Left	3	3
		Extended	1	1
	Facing Holder	1	1	
Boring Holder	I.D Holder	Single	3	3
		Long (SET)	-	-
Driven Holder	Straight Mill Holder	Standard	2	2
	Angular Mill Holder	Standard	2	2
Socket	Boring	Ø20 (Ø3/4")	1	1
		Ø25 (Ø1")	1	1
		Ø32 (Ø1 1/4")	1	1
		Ø40 (Ø1 1/2")	1	1
		Ø50 (Ø2")	1	1
		Ø60 (Ø2 1/4")	1	1
	Drill	MT 3	Opt	Opt
		MT 4	Opt	Opt
		MT 5	Opt	Opt
	ER Collet		Opt	Opt
Adapter Set		1 Set	1 Set	



# SPECIFICATIONS

## Specifications

[ ]: Option

ITEM		KL7000LY	KL8000LY	
CAPACITY	Swing Over the Bed	mm(in)	Ø1,200 (47.2")	
	Swing Over the Carriage	mm(in)	Ø1,000 (39.4")	
	Max. Turning Dia.	mm(in)	Ø920 (36.2")	
	Max. Turning Length	mm(in)	3,250 (128")	
	Bar Capacity	mm(in)	Ø165 (6.5") Hydraulic : Ø239 (9.4"), Air/Independent : Ø319 (12.6")	
SPINDLE	Chuck Size	inch	Opt. [24"]	
	Spindle Bore	mm(in)	Ø181 (7.1")	
	Spindle Speed (rpm)	r/min	1,500	
	Motor (Max.)	kW(HP)	45 (60)	
	Torque (Max.)	N·m(lbf·ft)	6,928 (5,109.8)	
	Spindle Type	-	BELT+3STEP GEAR	
	Spindle Nose	-	A1-15	
C-axis Indexing	deg	0.001 *		
FEED	Travel (X/Y/Z)	mm(in)	500/220 (±110)/3,280 (19.7"/8.7" (±4.3")/129")	
	Rapid Traverse Rate (X/Y/Z)	m/min(ipm)	12/10/12 (472/394/472)	
	Slide Type	-	BOX GUIDE	
TURRET	No. of Tools	ea	12	
	Tool Size	OD	mm(in)	□32 (1.3")
		ID	mm(in)	Ø80 (3.1")
	Indexing Time	sec/step	0.3	
LIVE TOOL	Milling Tool Speed (rpm)	r/min	3,000	
	Motor (Max/Cont.)	kW(HP)	11/7.5 (15/10)	
	Torque (Max/Cont.)	N·m(lbf·ft)	140/95.4 (103.3/70.4)	
	Collet Size	mm(in)	Ø34 (1.3") (ER50)	
	Type	-	BMT85	
TAIL STOCK	Taper	-	MT6 (Built-in)	
	Quill Dia.	mm(in)	Ø180 (7.1")	
	Quill Travel	mm(in)	200 (7.9")	
	Travel	mm(in)	3,200 (126")	
TANK CAPACITY	Coolant Tank	ℓ (gal)	620 (163.4)	
	Lubricating Tank	ℓ (gal)	4.0 (1.1)	
POWER SUPPLY	Electric Power Supply	kVA	55	
	Thickness of Power Cable	mm <sup>2</sup>	Over 50	
	Voltage	V/Hz	220/60 (200/50)	
MACHINE	Floor Space (L×W)	mm(in)	7,300×3,270 (287.4"×128.7")	
	Height	mm(in)	2,950 (116.1")	
	Weight	kg(lb)	24,500 (54,013)	
NC	Controller	-	FANUC 32i-B [FANUC i Series - Smart Plus]	

※ Prior consultation is required when applying spindle contouring control for gear driven spindle.

\*) Using 50Hz voltage instead of 60Hz may lower the output of motors. (excluding servo motors and inverter motors)

Specifications are subject to change without notice for improvement.

# CONTROLLER

## FANUC 32i-B

[ ]: Option

Controlled axis / Display / Accuracy Compensation	
Control axis	2 axis (X, Z) / 3 axis (X, Z, C) / 4 axis (X, Z, Y, C) 5 axis (X, Z, B, C, A) / 6 axis (X, Z, Y, B, C, A)
Simultaneously controlled axis	2 axis [Max. 4 axis]
Designation of spindle axis	4 axis (1 path), 6 axis (2 path Total)
Least setting Unit	X, Z, Y, B axis : 0.001 mm (0.0001 inch) C, A axis : 0.001 deg
Least input increment	X, Z, Y, B axis : 0.001 mm (0.0001 inch) C, A axis : 0.001 deg
Inch / Metric conversion	G20 / G21
High response vector control	
Interlock	All axis / Each axis
Machine lock	All axis
Backlash compensation	± 0 ~ 9999 pulses (Rapid traverse / Cutting feed)
Position switch	
LCD / MDI	10.4 inch color LCD
Feedback	Absolute motor feedback
Stored stroke check 1	Over travel
Stored stroke check 2, 3	
PMC axis control	
Operation	
Automatic operation (Memory)	
MDI operation	
DNC operation	Needed DNC software / CF card
Program restart	
Wrong operation prevention	
Program check function	Dry run, Program check
Single block	
Search function	Program Number / Sequence Number
Interpolation functions	
Nano interpolation	
Positioning	G00
Linear interpolation	G01
Circular interpolation	G02, G03
Exact stop mode	Single : G09, Continuous : G61
Dwell	G04, 0 ~ 9999.9999 sec
Skip	G31
Reference position return	1st reference : G28 2nd reference : G30 Ref. position check : G27
Thread synchronous cutting	
Thread cutting retract	
Variable lead thread cutting	
Multi / Continuous threading	
Feed function / Acc. & Dec. control	
Manual feed	Rapid traverse Jog : 0~2,000 mm/min (79 ipm) Manual handle : x1, x10, x100 pulses Reference position return
Cutting Feed command	Direct input F code
Feedrate override	0 ~ 200% (10% Unit)
Rapid traverse override	F1%, F25%, 50%, F100%
Override cancel	
Feed per minute	G98
Feed per revolution	G99
Look-ahead block	1 block
Program input	
Tape Code	EIA / ISO
Optional block skip	1 ea
Program stop / end	M00, M01 / M02, M30
Maximum command unit	± 999,999,999 mm (± 99,999,999 inch)
Plane selection	X-Y : G17 / Z-X : G18 / Y-Z : G19
Workpiece coordinate system	G52, G53, 6 pairs (G54 ~ G59)
Manual absolute	Fixed ON
Programmable data input	G10
Sub program call	10 folds nested
Custom macro	#100 ~ #149, #500 ~ #549
G code system	A
Programmable mirror image	G51.1, G50.1
G code preventing buffering	G4.1
Multiple repetitive cycles I, II	
Program input	

Canned cycle for turning	
Manual Guide i	Conversational auto program
Auxiliary function / Spindle speed function	
Auxiliary function	M 4 digit
Level-up M Code	High speed / Multi / Bypass M code
Spindle speed function	S 4 digit , Binary output
Spindle override	0% ~ 150% (10% Unit)
Multi position spindle orientation	M19
Rigid tapping	
Constant surface speed control	G96, G97
Tool function / Tool compensation	
Tool function	T 2 digit + Offset 2 digit
Tool life management	
Tool offset pairs	32 pairs
Tool nose radius compensation	G40, G41, G42
Geometry / Wear compensation	
Direct input of offset measured B	
Editing function	
Part program storage size	640m (256KB)
No. of registerable programs	500 ea
Program protect	
Background editing	
Extended part program editing	Copy, move and change of NC program
Memory card program edit	
Data input / output & Interface	
I/O interface	CF card, USB memory Embedded Ethernet interface
Screen hard copy	
External message	
External key input	
External workpiece number search	
Automatic data backup	
Setting, display and diagnosis	
Self-diagnosis function	
History display & Operation	Alarm & Operator message & Operation
Run hour / Parts count display	
Maintenance information	
Actual cutting feedrate display	
Display of spindle speed / T code	
Graphic display	
Operating monitor screen	Spindle / Servo load etc.
Power consumption monitoring	Spindle & Servo
Spindle / Servo setting screen	
Multi language display	Support 20 languages
Display language switching	Selection of 5 optional Languages
LCD Screen Saver	Screen saver
Unexpected disturbance torque	BST (Back spin torque limit)
Function for machine type	
Cs contour control (C & A axis)	Mill, MS, Y, SY, LF-Mill, TTMS, TTSY
Polar coordinate interpolation	Mill, MS, Y, SY, LF-Mill, TTMS, TTSY
Cylindrical interpolation	Mill, MS, Y, SY, LF-Mill, TTMS, TTSY
Canned cycle for drilling	Mill, MS, Y, SY, LF-Mill, TTMS, TTSY
Spindle orientation expansion	MS, SY TTS, TTMS, TTSY
Spindle synchronous control	MS, SY TTS, TTMS, TTSY
Torque control	MS, SY TTS, TTMS, TTSY
Y axis offset	Y, SY, TTSY
Arbitrary angular control	Y, SY, TTSY
Composite / Superimposed control	MS, SY TTS, TTMS, TTSY
Balance cutting	MS, SY TTS, TTMS, TTSY
Option	
Additional optional block skip	9 ea
Fast ethernet	Needed option board
Data server	Needed option board
Protection of data at 8 levels	
Tool offset pairs	64 pairs / 99 pairs / 200 pairs
Part program storage size	1280 m (512KB) / 2560m (1MB)
Polygon turning (2 Spindles)	Mill, MS, Y, SY, LF-Mill, TTMS, TTSY
Helical interpolation	
Dynamic graphic display	
Direct drawing dimension program	Including Chamfering / Corner R

Figures in inch are converted from metric values.

The FANUC controller specifications are subject to change based on the policy of company CNC supplying.

# CONTROLLER

## FANUC i Series - Smart Plus

[ ] : Option

Controlled axis / Display / Accuracy Compensation	
Control axis	2 axis (X, Z) / 3 axis (X, Z, C) / 4 axis (X,Z,Y,C) 5 axis (X, Z, B, C, A) / 6 axis (X, Z, Y, B, C, A) 7 axis (X1/Z1, X2/Z2, B2, C1/C2)
Simultaneously controlled axis	2 axis [Max. 4 axis]
Designation of spindle axis	3 axis [Max. 4 axis]
Least setting Unit	X, Z, Y, B axis : 0.001 mm (0.0001 inch) C, A axis : 0.001 deg
Least input increment	X, Z, Y, B axis : 0.001 mm (0.0001 inch) C, A axis : 0.001 deg
Inch / Metric conversion	G20 / G21
High response vector control	
Interlock	All axis / Each axis
Machine lock	All axis
Backlash compensation	± 0-9999 pulses (exc.Rapid traverse / Cutting feed)
Position switch	
LCD / MDI	15 inch LCD unit (with Touch Panel)
Feedback	Absolute motor feedback
Stored stroke check 1	Over travel
Stored stroke check 2, 3	
PMC axis control	
Operation	
Automatic operation (Memory)	
MDI operation	
DNC operation	Needed DNC software / CF card
Program restart	
Wrong operation prevention	
Program check function	Dry run
Single block	
Search function	Program Number / Sequence Number
Interpolation functions	
Nano interpolation	
Positioning	G00
Linear interpolation	G01
Circular interpolation	G02, G03
Exact stop mode	Single : G09, Continuous : G61
Dwell	G04, 0 ~ 9999.9999 sec
Skip	G31
Reference position return	1st reference : G28, 2nd reference : G30 Ref. position check : G27
Thread synchronous cutting	G33
Thread cutting retract	
Variable lead thread cutting	
Multi / Continuous threading	
Feed function / Acc. & Dec. control	
Manual feed	Rapid traverse Jog : 0~2,000 mm/min (79 ipm) Manual handle : x1, x10, x100 pulses Reference position return
Cutting Feed command	Direct input F code
Feedrate override	0 ~ 200% (10% Unit)
Rapid traverse override	1%, F25%, 50%, 100%
Override cancel	
Feed per minute	G98
Feed per revolution	G99
Look-ahead block	1 block
Program input	
Tape Code	EIA / ISO
Optional block skip	9 ea
Program stop / end	M00, M01 / M02, M30
Maximum command unit	± 999,999.999 mm (± 99,999.9999 inch)
Plane selection	X-Y : G17 / Z-X : G18 / Y-Z : G19
Workpiece coordinate system	G52, G53, 6 pairs (G54 ~ G59)
Manual absolute	Fixed ON
Programmable data input	G10
Sub program call	10 folds nested
Custom macro	#100 ~ #199, #500 ~ #999
G code system	A, B/C
Programmable mirror image	G51.1, G50.1
G code preventing buffering	G4.1
Direct drawing dimension program	Including Chamfering / Corner R
Conversational Program	SmartGuide-i

Program input	
Multiple repetitive cycles	I, II
Canned cycle for turning	
Auxiliary function / Spindle speed function	
Auxiliary function	M & 4 digit
Level-up M Code	High speed / Multi / Bypass M code
Spindle speed function	S & 5 digit, Binary output
Spindle override	0% ~ 150% (10% Unit)
Multi position spindle orientation	M19 (S##)
Rigid tapping	
Constant surface speed control	G96, G97
Tool function / Tool compensation	
Tool function	T & 2 digit + Offset 2 digit
Tool life management	
Tool offset pairs	128 pairs
Tool nose radius compensation	G40, G41, G42
Geometry / Wear compensation	
Direct input of offset measured B	
Editing function	
Part program storage size	5,120m (2MB)
No. of registerable programs	1,000 ea
Program protect	
Background editing	
Extended part program editing	Copy, move and change of NC program
Memory card program edit	
Data input / output & Interface	
I/O interface	CF card, USB memory Embedded Ethernet interface
Screen hard copy	
External message	
External key input	
External workpiece number search	
Automatic data backup	
Setting, display and diagnosis	
Self-diagnosis function	
History display & Operation	Alarm & Operator message & Operation
Run hour / Parts count display	
Maintenance information	
Actual cutting feedrate display	
Display of spindle speed / T code	
Graphic display	
Operating monitor screen	Spindle / Servo load etc.
Power consumption monitoring	Spindle & Servo
Spindle / Servo setting screen	
Multi language display	Support 24 languages
Display language switching	Selection of 5 optional Languages
LCD Screen Saver	Screen saver
Unexpected disturbance torque	BST (Back spin torque limit)
Function for machine type	
Cs contour control (C & A axis)	Mill, MS, Y, SY, LF-Mill, TTMS, TTSY
Polar coordinate interpolation	Mill, MS, Y, SY, LF-Mill, TTMS, TTSY
Cylindrical interpolation	Mill, MS, Y, SY, LF-Mill, TTMS, TTSY
Polygon turning (2 Spindles)	Mill, MS, Y, SY, LF-Mill, TTMS, TTSY
Canned cycle for drilling	Mill, MS, Y, SY, LF-Mill, TTMS, TTSY
Spindle orientation expansion	MS, SY TTS, TTMS, TTSY
Spindle synchronous control	MS, SY TTS, TTMS, TTSY
Torque control	MS, SY TTS, TTMS, TTSY
Y axis offset	Y, SY, TTSY
Arbitrary angular control	Y, SY, TTSY
Composite / Superimposed control	MS, SY, TTS, TTMS, TTSY
Balance cutting	TTS, TTMS, TTSY
Option	
Fast ethernet	Needed option board
Data server	Needed option board
Protection of data at 8 levels	
Tool offset pairs	200 pairs
Helical interpolation	
Optional block skip	40 ea, 200 ea (AICC II)

Figures in inch are converted from metric values.

The FANUC controller specifications are subject to change based on the policy of company CNC supplying.

# GLOBAL NETWORK



## WIA MACHINE TOOLS

**Headquarter / R&D Center** 106, Yongji-ro, Seongsan-gu, Changwon-si, Gyeongsangnam-do, Republic of Korea TEL : +82 55 225 9999

**Overseas Sales Team** 13, Iljik-ro 12beon-gil, Gwangmyeong-si, Gyeonggi-do, Republic of Korea TEL : +82 55 225 9645

### OVERSEAS OFFICES

**America corp.** 450 Commerce Blvd, Carlstadt, NJ 07072, USA TEL : +1-201-987-7298

**Europe GmbH** Alexander-Fleming-Ring 57, 65428 Russelsheim Germany TEL : +49-0-6142-9256-0

**China** Company No.16 Fenghuang Road, Fenghuang Town, Zhangjiagang City, Jiangsu Province, China TEL : +86-21-6427-9885

**CIS Branch Office** 050051, Kazakhstan, Almaty, Elebekova street 10, B.3 Office no. 103 TEL : +7-727-355-7133

**India Branch Office** #4/169, 1st Floor, LOTTE BLDG, Rajiv Gandhi Salai, (OMR), Kandanchavadi, Chennai - 600096, Tamilnadu, India TEL : +91-76-0490-3348

# WIA MACHINE TOOLS



home page



facebook



youtube



instagram



linkedin